

ASTM C39

Standard Test Method for Compressive Strength of
Cylindrical Concrete Specimens

**Understanding ASTM International Test Procedures
for Cement and Concrete - Staying Up to Standard**

Anthony F. Bentivegna, Ph.D.
April 27-28, 2015



Acknowledgments

Slides Adapted from ASTM International



Outline

- ▶ Objectives
- ▶ Related Procedures
- ▶ Scope/Significance and Use
- ▶ Identify Necessary Equipment
- ▶ Measure Properties of Specimens
- ▶ Procedure
- ▶ Reporting and Failure Modes

www.CTLGroup.com



Objectives

- ▶ Define Key Terminology
- ▶ Identify Necessary Equipment
- ▶ Understand Sources of Errors
- ▶ Understand Limitations of Procedure

www.CTLGroup.com 

Related Procedures

- ▶ ASTM C131 – Practice for Making and Curing Concrete Test Specimens in the Field
- ▶ ASTM C42 – Test Method for Obtaining and Testing Drilled Cores and Sawed Beams of Concrete
- ▶ ASTM C192 – Practice for Making and Curing Concrete Test Specimens in the Laboratory
- ▶ ASTM C617 Practice for Capping Cylindrical Concrete Specimens
- ▶ ASTM C670 – Practice for Preparing Precision and Bias Statements for Test Methods for Construction Materials
- ▶ ASTM C873 – Test Method for Compressive Strength of Concrete Cylinders Cast in Place in Cylindrical Molds

www.CTLGroup.com 

Related Procedures

- ▶ ASTM C1077 – Practice for Agencies Testing Concrete and Concrete Aggregates for Use in Construction and Criteria for Testing Agency Evaluation
- ▶ ASTM C1231 – Practice for use of Unbonded Caps in Determination of Compressive Strength of Hardened Concrete Cylinders
- ▶ ASTM E4 – Practices for Force Verification of Testing Machines
- ▶ ASTM E74 – Practice of Calibration of Force- Measuring Instruments for Verifying the Force Indication of Testing Machines

www.CTLGroup.com 

Scope/Significance and Use

- ▶ **Scope:** This test method covers determination of compressive strength of cylindrical concrete specimens such as molded cylinder and drilled cores. It is limited to concrete having a density in excess of 800 kg/m³.
- ▶ **Significance and Use:** Care must be exercised in the interpretation of the significance of compressive strength determinations by this test method since strength is not a fundamental or intrinsic property of concrete made from given materials. Values obtained will depend on the size and shape of the specimen, batching, mixing, procedures, the methods of sampling, molding, and fabrication and the age, temperature, and moisture conditions during curing.

www.CTLGroup.com



Significance and Use

- ▶ This test method is used to determine the compressive strength of,



Drilled cores



Field or laboratory molded cylinders

www.CTLGroup.com



Significance and Use

- ▶ Specimens can be tested using bonded or unbonded end caps.



www.CTLGroup.com



Significance and Use

- ▶ Results can be used as a basis of quality control for,
 - proportioning
 - mixing and placing operations
 - compliance with specifications
 - admixture effectiveness
 - other uses

www.CTLGroup.com 

Significance and Use

- ▶ Individuals who test concrete cylinders for acceptance shall meet the concrete laboratory technician requirements of ASTM Practice C 1077.
 - must pass a performance exam that is evaluated by an independent examiner
 - ACI certification will satisfy this requirement

www.CTLGroup.com 

Summary of Test Method

- ▶ Axial compressive load is applied to a cylindrical specimen until it ruptures.
- ▶ Compressive strength is computed by dividing the maximum applied load (P) by the cross-sectional area of the specimen (A).

$$\text{Strength} = \frac{P}{A} \text{ kg/m}^3$$

www.CTLGroup.com 

Apparatus: Testing Machine

- ▶ Testing machine
- ▶ Requirements:
 - Apply load continuously without shock
 - Have sufficient capacity
 - Load Rate of 0.25 ± 0.05 MPA/s
 - Have two steel bearing blocks with hardened faces
 - Error in actual measured load shall not exceed $\pm 1\%$ of the indicated load



www.CTLGroup.com 



Upper bearing shall be a spherically seated block

Lower bearing shall be a solid block

Platen can serve as lower block

www.CTLGroup.com 

Apparatus: Testing Machine

- ▶ The minimum horizontal dimension of a bearing block must be at least 3% greater than the specimen diameter.
 - about 157 mm for a 150 mm diameter cylinder



www.CTLGroup.com 

Apparatus: Testing Machine

- ▶ The maximum diameter of the upper bearing block shall be,
 - 165 mm for 100 mm diameter specimens
 - 255 mm for 150 mm diameter specimens

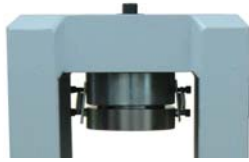

www.CTLGroup.com



Apparatus: Testing Machine

- ▶ The lower bearing block shall be at least,
 - 25 mm thick when new
 - 22.5 mm thick after any resurfacing



www.CTLGroup.com



Apparatus: Testing Machine

- ▶ The bearing surfaces shall be plane within,
 - 0.02 mm across any 150 mm for blocks ≥ 150 mm in diameter
 - 0.02 mm for blocks < 150 mm in diameter



www.CTLGroup.com



Verify Surfaces are Plane



www.CTLGroup.com 

Apparatus: Testing Machine

- ▶ Testing machines must be calibrated,
 - when originally installed
 - after being relocated
 - at least annually, but not to exceed 13 months
 - after making repairs or adjustments that affect the load application system
 - whenever there is a question of accuracy

www.CTLGroup.com 

Apparatus: Other

- ▶ This test requires the use of several devices which are not listed in the standard.
 - feeler gauges and straight edge to check bearing blocks and ends of specimen for plane
 - square and ruler to check ends of specimen for perpendicularity
 - caliper to measure specimen dimensions



www.CTLGroup.com 

Specimens: Measure Diameter

- ▶ When measuring the diameter of a specimen,
 - take two measurements at right angles to each other
 - measure near mid-height
 - average the two values
 - record the average diameter to nearest 0.25 mm



www.CTLGroup.com 

Specimens: Diameter

- ▶ The individual diameter readings for a cylinder may not differ by more than 2%.
 - do not test cylinders that violate this requirement

$$\left(\frac{d_{\text{large}} - d_{\text{small}}}{d_{\text{small}}} \right) \times 100\% \leq 2\%$$

www.CTLGroup.com 

Specimens: Average Dimensions

- ▶ An average diameter can be used to represent all specimens in a group.
 - all specimens must be fabricated from a single lot of reusable, or single use, molds
 - the lot must have a record of producing test specimens with average diameters within ± 0.5 mm of each other
- ▶ Otherwise, the average diameter of each specimen must be measured and used individually.

www.CTLGroup.com 

Specimens: Average Dimensions

- ▶ When an average diameter can be used,
 - measure 1 cylinder for each 10 in the group
 - measure no fewer than 3 cylinders per day
 - compute an average diameter using the individual diameters from all measured cylinders
 - compute a cross-sectional area based on the average diameter
 - use the resulting area to determine strength for all cylinders in the group

www.CTLGroup.com



Specimens: Perpendicularity

- ▶ Cylinder ends must be perpendicular to the cylinder length within 0.5°.
 - 0.5° is approximately equal to a 1 mm inch gap at the end of a 100 mm length



www.CTLGroup.com



Specimens: Plane Ends

- ▶ Both ends of a cylinder must be plane within 0.050 mm.
 - saw, grind or cap an end to meet this requirement
 - cap ends per ASTM C167 (sulfur) or C1231 (neoprene pad)



www.CTLGroup.com



Specimens: Optional - Determine Density

- ▶ When density is to be measured,
 - measure the mass after removing any surface moisture and prior to capping
 - use one of two methods to compute the volume

$$\text{Density} = \frac{\text{Mass}}{\text{Volume}} \text{ kg/m}^3$$

www.CTLGroup.com 

Specimens – Optional: Volume - Method 1

- ▶ Measure the cylinder diameter and length.
 - find the average diameter, d, in mm
 - measure the length at three evenly spaced locations around the circumference, record to the nearest 1 mm
 - compute the average length, L, and record to the nearest 1 mm



$$\text{Volume}_1 = \left[(L) \left(\pi \left(\frac{d}{2} \right)^2 \right) \right] \left(\frac{1}{1000} \right) \text{ m}^3$$

www.CTLGroup.com 

Specimens - Optional: Volume - Method 2

- ▶ Measure the cylinder mass in air and when submerged under water.
 - mass and volume must be consistent with the units for density
 - water should be at 23° ± 2.0°C
 - water density based on its temperature



$$\text{Volume}_2 = \frac{(\text{Mass}_{\text{air}} - \text{Mass}_{\text{water}})}{\text{Density of water}} \text{ m}^3$$

www.CTLGroup.com 

Density of Water

°C	Density (kg/m ³)
21	998.0
22	997.8
23	997.5
24	997.3
25	997.0

www.CTLGroup.com

Procedure: Conditioning Specimen

- ▶ Moist-cured specimens shall be,
 - tested as soon as practical after removal from moisture storage
 - kept moist until tested
 - tested while in the moist condition



www.CTLGroup.com

Procedure: Time Tolerance

- ▶ Test all specimens for a given age within the permitted tolerance for time.

Test Age	Tolerance
24 hours	± 0.5 hours
3 days	± 2 hours
7 day	± 6 hours
28 day	± 20 hours
90 day	± 2 days

www.CTLGroup.com

Procedure: Placing the Specimen

- ▶ Align the lower bearing block with the upper block.
- ▶ Wipe clean the surfaces of the bearing blocks and ends of the test specimen.
- ▶ Verify that the load indicator is set to zero.
 - adjust the indicator as necessary

www.CTLGroup.com 

Procedure: Placing the Specimen

- ▶ Position the specimen on the lower block and align with the line of action of the load from the testing machine.



www.CTLGroup.com 

Procedure: Block Seating

- ▶ As the upper bearing block contacts the specimen, gently rotate the movable portion of the block to insure uniform seating on the specimen.

www.CTLGroup.com 

Procedure: Block Seating



www.CTLGroup.com 

Procedure: Rate of Loading

- ▶ Apply load continuously and without shock.
- ▶ Loading shall be at a rate corresponding to a stress rate of 0.25 ± 0.05 MPa/sec.
 - this rate shall be maintained at least for the second half of the anticipated maximum load
 - a higher rate is permitted for the first half of the anticipated maximum load
- ▶ Do not adjust the rate as the maximum load is approached.

www.CTLGroup.com 

Procedure: Loading

- ▶ Continue to apply load until the
 - load begins to steadily decrease
 - specimen displays a well-defined fracture pattern
- ▶ When unbonded caps are used, continue to load until there is certainty that the ultimate capacity has been reached.
- ▶ Automatic shut-off of a testing machine is prohibited until the load has dropped below 95% of the peak load.

www.CTLGroup.com 

Procedure

- ▶ Record the,
 - maximum applied load
 - type of fracture pattern from Figure 2 in the standard
- ▶ If the fracture pattern is not depicted in Figure 2, sketch and describe the fracture.



www.CTLGroup.com 

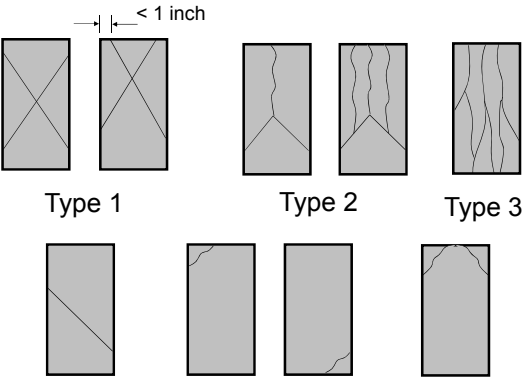

→ | ← < 1 inch

Type 1 Type 2 Type 3

Type 4 Type 5 Type 6

Fracture Types

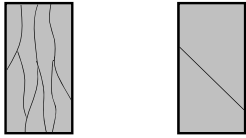

Type 3 Type 4

(Adapted from Figure 2)

www.CTLGroup.com 

Fracture Types

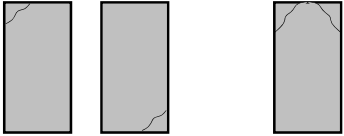

Type 5 Type 6

(Adapted from Figure 2)

www.CTLGroup.com **CTLGROUP**

Procedure: Low-Strength Documentation

- ▶ When the measured strength is less than expected, make note of,
 - the presence of large air voids
 - any evidence of segregation
 - whether fracture is through or around the coarse aggregate
 - how the ends of the specimen were prepared

www.CTLGroup.com **CTLGROUP**

Calculations

- ▶ Compressive Strength, MPa
 - report result to the nearest 0.1 MPa

$$\frac{\text{Maximum Load}}{\text{Cross - sectional Area}} = \frac{P}{A}$$

www.CTLGroup.com **CTLGROUP**

Calculations

▶ When $L/d \leq 1.75$, multiply the compressive strength by the appropriate correction factor.

L/d	Correction Factor
1.75	0.98
1.50	0.96
1.25	0.93
1.00	0.87

interpolate as necessary

www.CTLGroup.com 

Calculations

▶ Density, kg/m^3

- report result to the nearest 10 kg/m^3

$$\text{Density} = \frac{\text{Mass}}{\text{Volume}} \text{ kg/m}^3$$

www.CTLGroup.com 

Calculations

▶ Density, kg/m^3

$$\text{Volume}_1 = \left[(L) \left(\frac{d}{2} \right)^2 \right] \left(\frac{1}{1000} \right) \text{ m}^3$$

$$\text{Volume}_2 = \frac{(\text{Mass}_{\text{air}} - \text{Mass}_{\text{water}})}{\text{Density of water}} \text{ m}^3$$

www.CTLGroup.com 

Report

- ▶ Report the following information.
 - identification number
 - diameter in inches
 - length, if outside range of 1.8(d) to 2.2(d)
 - cross-sectional area, mm²
 - maximum load, kilonewtons
 - compressive strength to nearest 0.1 MPa

www.CTLGroup.com 

Report

- ▶ Report the following information.
 - type of fracture
 - defects in the specimen or caps
 - age of the specimen
 - when determined, density to the nearest 10 kg/m³

www.CTLGroup.com 

Questions & Answers

Cubes vs. Cylinders

► **Why compressive strength of concrete cube is greater than that of cylinder?**

- Contact area of cube mold with the upper platen in the testing machine is more which results in more confinement, and
- More confinement resist against specimen expansion resulting in more compressive strength.
- Cube strengths are 15-25% greater than Cylinder

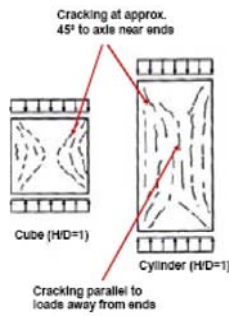

www.CTLGroup.com